

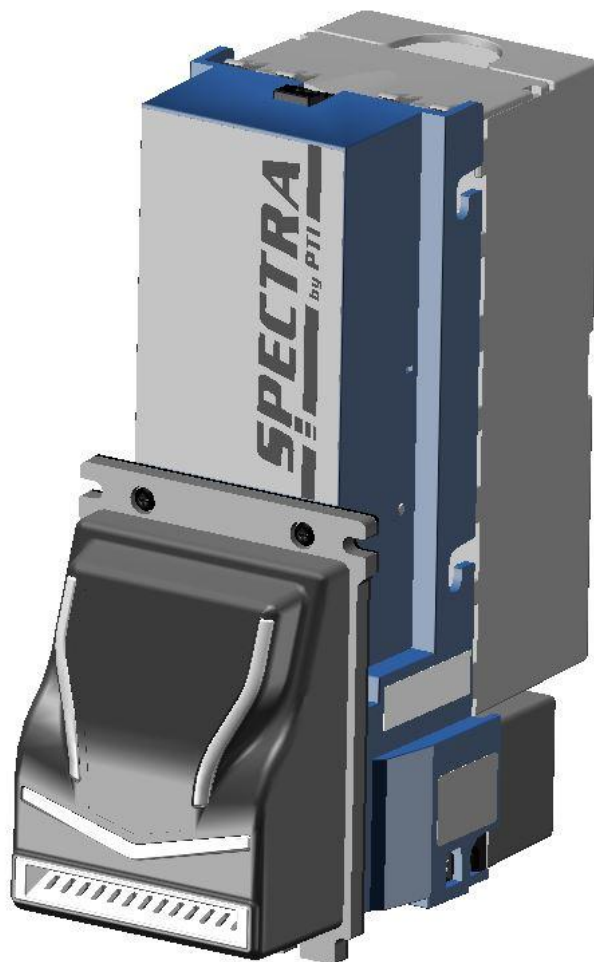

SPECTRA
by PTI

APEX SPECTRA BILL ACCEPTOR INSTALLATION/OPERATION MANUAL



Pyramid Technologies, Inc.
1907 S Hobson Suite 122
Mesa, Arizona 85204 USA
480-507-0088 FAX: 480-507-1922
www.pyramidacceptors.com

Rev. B 9/2/2014



Apex SPECTRA

The Apex SPECTRA has been added to the Apex line of products that showcases a highly luminescent bezel design with drains for dust and debris. This is in conjunction with the Dual Configuration mode that customers have come to rely on: The 8-position DIP switch on the bottom of the unit can be used for quick configuration. By turning all switches to the "OFF" position, the Apex SPECTRA may also be configured via PC or Configuration Card just like the Apex 7000.

Product Overview

The Pyramid Technologies, Inc. (PTI) Apex SPECTRA bill acceptor is designed for indoor use in the amusement, gaming, lottery, vending and kiosk markets.

Note: "VFM, VFM3S, VFM5S, GL5, LE3000 and Mars" are Trademarks of MEI, International. "HSV-300" is a Trademark of Gamemax. "Smiley" is a Trademark of Innovative Technologies. Coinco is a Trademark of Coinco Inc.

Apex SPECTRA Acceptor Features

- Highly luminescent bezel and haloed bill entry.
- Bezel drains that enhance dust and debris prevention.
- High security against fraudulent bills.
- Flash downloadable software using a PRO2 handheld programmer or Windows PC.
- On-board pushbutton/LED and advanced diagnostics via PC.
- Many interfaces available: Pinouts compatible with other manufacturers' bill acceptors.
- Robust dual-stage optical anti-stringing.
- Simple configuration and setup (including DIP Switch Configuration on Apex SPECTRA).
- 12 VDC (+/- 10%) operation is standard. Optional 24 VAC and 120 VAC operation available.
- Removable bill path for easy cleaning.
- Can handle bills up to 72 mm wide for foreign applications.
- 200, 500 bill cassettes available (stackered model).
- Auto-calibration - Never needs to be calibrated.

Product Specifications

Operating Voltage: 12 VDC (+/- 10%) standard, optional 120 VAC or 24 VAC supply available.

Operating Currents: **Idle:** 180 mA **Accepting:** 500 mA **Stalled:** 1.50 A.

Operating Temperature: 0C – 60C, 90 % non-condensing humidity.

Acceptance Rate: Greater than 95%, including second time insertion of a rejected bill.

Acceptance Speed: Approx. 20 bills per minute.

Sensor Array: 8 Optical Sensors, one Magnetic Head. Mag. Head is standard on \$50, \$100 acceptor only.

Bills Accepted: Up to 12 bills in all four directions.

Net Weight: Stackered Model..... 2.3 lbs./1.04 kg.

Warranty: 2 years, parts and labor (see Warranty Section).

Explanation of Apex SPECTRA Model Numbers

To order any Apex SPECTRA acceptor, use the following order information:

Series	Model	Type	Cashbox	P.S./Comm.	Country
APEX	- SX00-	U	X	X	- XXX

Model

S400 - No Mag. Head (\$1-\$20 for US model and some foreign models)

S600 - Mag. Head (\$1-\$100 for US model and some foreign models)

Type

U- Upstacker

Cashbox

A- Non-Lockable 200 Note Plastic Cassette (02AA30N2)

C – Non-Lockable 500 Note Plastic Cassette (02AA30N5)

D- Lockable 500 Note Plastic Cassette (02AA30L5)

P.S./Comm. (Power Supply/Communication Options)

1- 12 VDC (No harness supplied)

3- 120 VAC high level operational supply (Ships with 9-pin AC harness.)

4- MDB Option (Ships with MDB harness)

9- 24 VAC Version. (Ships with 9-pin 24 VAC harness)

Country Code

Follows ISO three (3) digit Country Code- Example USA = United States

Serial Number Description

Example Serial Number: S/N 1438 00001

In this example, the first two digits are the year of manufacture (2014). The week of manufacture is week **38** of 2014. The sequential production serial number is **00001**.

Dimensional Drawings- Stacked and Stackerless Cassette Styles

The stacked Apex SPECTRA bill acceptor can be ordered with either a 200 or a 500 bill cassette. Locking cassettes are also available. The cassette has a cover that can easily be opened to retrieve the bills without removal of the cassette from the acceptor. For Dimensional Drawings, please visit our website at www.pyramidacceptors.com in the Bill Acceptors section.

Accessories

The following is a list of optional accessories available from Pyramid Technologies, Inc. See our website for additional items, photos, and information about accessories.

Description

Part Number

PRO-2 Handheld Programmer

PRO2

The PRO-2 makes it easy to update bill acceptors. Simply pre-load the PRO-2 with the desired firmware version, plug it into the SPECTRA, and the update happens automatically. The PRO-2 is powered by the bill acceptor when connected, so there is no need for a battery or power supply.

USB Flash Download Cable

P/N 05AA0026

The USB Flash Download Cable is used to update bill acceptors with new firmware via Windows PC, and perform Configuration and Diagnostic functions using the Acceptor Tools software (free download from <http://www.pyramidacceptors.com>).

Wall Plug Harness

P/N 05AA0012

For acceptors with the 120VAC power supply, this will adapt the 9-pin connector to a wall plug to power the acceptor using a standard 120VAC wall outlet.

Acceptor I/O Harness, Generic

P/N 05AA0002

This is an 18-pin harness to interface to the SPECTRA bill acceptor I/O. All 18 wires are present. Harness is 36" long.

HSV-300™ Compatible I/O Harness

P/N 05AA0007

This harness plugs into our 18-pin I/O connector on the SPECTRA bill acceptor and allows the user to connect the acceptor directly to a harness originally intended for an HSV-300 acceptor. This harness is a seven (7) pin connector and is 6" long

RS-232 Communication Harness

P/N 05AA0009

This harness is needed for true RS-232 communication. The harness comes with a DB9 connector on 36" of cable, as well as a hard drive connector on 36" of cable to obtain 12 VDC power for the bill acceptor from the PC. Order Document "RS232" for more details (or visit our web site). The "Download" section of our web site has a demo program which you can download to try out the PC interface.

USB Communication Harness

P/N 05AA0023

This harness is needed for USB communication. The harness comes with a USB connector on 36" of cable, as well as a hard drive connector on 36" of cable to obtain 12 VDC power for the note acceptor from the PC. Order Document "RS232" for more details (or visit our web site). The "Download" section of our web site has a demo program which you can download to try out the PC interface.

Please visit our website (www.pyramidacceptors.com) for more harness options.

Limited Warranty

The Apex SPECTRA bill acceptor is warranted for a period of two (2) years from date of original invoice. This warranty extends to the original purchaser of the warranted product and each transferee owner of the product, during the term of the warranty. During the warranty period, manufacturer will repair or replace (at manufacture's option) any parts, up to and including the complete acceptor, which fail to function properly because of defects in material or workmanship. This warranty covers bill acceptors only, which are designed to accept genuine currency.

Manufacturer is not responsible for any consequential damage or performance degradation that results from counterfeit currency or foreign objects inserted into the bill acceptor. The product to be repaired under warranty must be delivered, inbound freight prepaid to an authorized service center. Upon request, the owner must show proof of purchase when submitting equipment for service during the warranty period. Repair or installation at the owner's location is not included in warranty. During the warranty period, manufacturer will pay all outbound ground freight charges to the owner's location. Special handling or shipping charges must be assumed by the owner. Manufacturer will not be liable for any consequential damages as a result of defects in material or workmanship. Any written or applied warranty of this product is strictly limited to the refund of the cost of goods purchased. Damage due to negligence, accidents, electrical overload, misuse, abuse, vandalism, or an act of God, is not covered by this warranty. Any alteration of the product after manufacture voids the warranty in its entirety.

Shipping Damage

When a product is returned to the owner after service, only consignee (the person or company receiving the bill acceptor) can file a claim against the carrier for concealed damages. Therefore, unpack immediately. Notify the delivery carrier of damages and request immediate inspection. Send a letter of intent to file claim to the carrier within 72 hours from the time of receipt. Send a copy of this letter to the shipper.

Service

For service information, please contact Pyramid Technologies, Inc. for a Service Center near you. For any items returned under warranty or for repair, complete written information including the serial and model number as well as a description of the malfunction or defects must be submitted to the Service Center when requesting a Return Material Authorization number (RMA number). Owner accepts full responsibility for any return without prior authorization. The RMA number must be displayed on the exterior of the returned product carton(s).

Unpacking the Bill Acceptor

Immediately inspect the bill acceptor for damage when unpacking it. If the acceptor is damaged, place it back in its original carton along with the packing materials. Notify the carrier of damages and request an immediate inspection of the package. Send a letter of intent to file a claim to the carrier within 72 hours from time of delivery. Please also send a copy of this letter to the shipper. Only the person or company receiving the bill acceptor can file a claim against the carrier for concealed damages.

Installation/Mounting

The Apex SPECTRA bill acceptor has been designed to easily mount onto existing studs in OEM equipment.

To install the acceptor, disconnect all power to the machine. Connect the interface cable from the machine to the acceptor. (On 120 VAC units, connect the 9-pin power plug to the machine. Install the green ring terminal ground wire to a stud that is part of the grounded frame). Secure the harnesses in place using the provided tie wraps.

Configuration using a Windows PC: *Note: All Apex SPECTRA bill acceptors are pre-configured at the factory and may not need the configuration set. Please contact us at 480-507-0088 for questions.*

This method allows you to change the configuration of the SPECTRA acceptor easily. *For Apex SPECTRA, all DIP Switch positions must be set to OFF for PC Configuration.* Please visit our website under the Support Section for more details. Requires Acceptor Tools software (free download), and 05AA0026 USB Cable.

SWITCH	
1	ON: Bill 1 Enabled OFF: Bill 1 Disabled
2	ON: Bill 2 Enabled OFF: Bill 2 Disabled
3	ON: Bill 3 Enabled OFF: Bill 3 Disabled
4	ON: Bill 4 Enabled OFF: Bill 4 Disabled
ON →	
1 2 3 4 5 6 7 8	
← OFF	
5	ON: 4-Way Acceptance OFF: 1-Way Acceptance
6	ON: Always Enabled OFF: Harness Enabled*
7	ON: 4 Pulses per Dollar OFF: 1 Pulse per Dollar
8	ON: Fast Pulse OFF: Slow Pulse

*When Switch 6 is OFF (Harness Enabled, or Auto-Detect), Switches 7 & 8 have no effect.

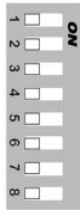

Configuration using the DIP Switches

For Apex SPECTRA models it is possible to set most configuration options quickly by toggling the 8 position DIP switch positions.

If **any** of the 8 positions are set to the “ON” position, the DIP Switch settings will override any configuration settings established by PC or Configuration Card.

If **all** of the DIP Switch positions are set to the “OFF” position (factory default), the DIP Switch Configuration is disabled, and the acceptor will revert to any configuration settings previously established by a Configuration Card, or by the Acceptor Tools PC Software.

Enabling Bill Denominations

Toggle DIP Positions 1 through 4 ON or OFF to enable or disable the first four bill denominations. For firmware with more than 4 bills (Bills 5 & 6, 7, ect.) will become enabled whenever Bill 4 is enabled.

Example: An Apex SPECTRA for USA normally accepts the \$1, \$5, \$10, and \$20 bills. To turn off the \$10 and \$20 so that only the \$1 and \$5 are accepted, simply toggle DIP Positions 1 & 2 to the ON position, and set 3 & 4 to OFF.

An Apex SPECTRA for Australia and Canada normally accepts the \$5, \$10, \$20, \$50 and \$100 bills. To turn off the \$50 and \$100, simply toggle DIP Positions 1, 2, & 3 to the ON position, and set 4 to OFF.

Limiting Acceptance Directions

To accept bills in all four insertion directions, toggle DIP Position 5 to the ON position. To limit acceptance to left-end, face-up only insertion, toggle DIP Position 5 to the OFF position.

Acceptor Enable Mode

To operate in Always Enabled Pulse mode, toggle DIP Position 6 to the ON position. For other interface modes in which the acceptor is enabled or disabled by equipment (Standard Pulse Mode, \$1&\$5 Credit Line, MDB, 600-Baud Serial, etc.), toggle DIP Position 6 to the OFF position.

Pulses Per Dollar Setting (only valid if DIP 6 is ON)

For Quarter-based equipment (in which one pulse is worth \$0.25), toggle DIP Position 7 to ON to set 4 Pulses per Dollar. Toggle DIP 7 to OFF for one pulse per dollar.

Pulse Speed Setting (only valid if DIP 6 is ON)

Toggle DIP Position 8 to ON for Fast Pulse (50ms on, 50ms off), or OFF for Slow Pulse (50ms on, 300ms off).

Configuration using the Configuration Card

The Apex SPECTRA acceptor can be configured using a Configuration Card. A Configuration Card is printed on the last page of this manual. To use this card, first make a copy using a standard black and white laser or bubble jet copier. Make sure the copy is printed on white copier paper and is the same size as the original card. Note: Copiers occasionally change the size of printed materials. This is why you should compare the copied card to the original card. Once you have copied the card in the manual, carefully cut it out along the edge lines.

The Configuration Card below is an example only! Use the card in the back of this manual!

INSERT THIS SIDE UP, THIS END FIRST
USE BLACK INK, FILL OVALS COMPLETELY

<p>section 1</p> <p>Pulse/Serial: <input type="text"/> \$185/ <input type="text"/> Credit Lines</p> <p>MDB: <input type="text"/> \$120/ <input type="text"/> Credit Lines</p> <p>RS-232: <input type="text"/> Always Enabled</p> <p>Parallel: <input type="text"/> HI</p> <p>Special 1: <input type="text"/> Special 2: <input type="text"/></p> <p>Select only one interface Type</p>	
<p>section 2</p> <p>Pulses per Dollar (sum of selected values)</p> <p><input type="text"/> 64 <input type="text"/> 4 <input type="text"/></p> <p><input type="text"/> 32 <input type="text"/> 2 <input type="text"/></p> <p><input type="text"/> 16 <input type="text"/> 1 <input type="text"/></p> <p><input type="text"/> 8 <input type="text"/> None <input type="text"/></p> <p>Example: For 50 and fill in the ovals for 32, 16, and 2. (32+16+2 = 50)</p>	<p>section 3</p> <p>Pulse Speed: <input type="text"/> Slow <input type="text"/> Fast</p> <p>Lighted Bezel: <input type="text"/> Solid On <input type="text"/> Flashing</p>
<p>section 4</p> <p>Select Bills to Enable</p> <p><input type="text"/> Bill 1 (\$1) <input type="text"/> Bill 2 (\$5)</p> <p><input type="text"/> Bill 3 (\$10) <input type="text"/> Bill 4 (\$20)</p> <p><input type="text"/> Bill 5 (\$50) <input type="text"/> Bill 6 (\$100)</p> <p><input type="text"/> Bill 7 <input type="text"/> Bill 8</p> <p><input type="text"/> Bill 9 <input type="text"/> Bill 10</p> <p><input type="text"/> Bill 11 <input type="text"/> Bill 12</p> <p>Example: To accept USA 10, 20, and 50 bills, fill the ovals for Bill 1, Bill 2, and Bill 3.</p>	<p>section 5</p> <p>Security Level: <input type="text"/> High <input type="text"/> Low</p> <p>Face up: <input type="text"/> All 4 <input type="text"/> Ways</p> <p>Insert Direction: <input type="text"/> Left <input type="text"/> 1st</p>

This Configuration Card should be printed on standard copy paper, measuring 6.0 x 2.6 inches (152 x 66 mm).
If printing from a .PDF file, turn off the "shrink to fit" option in your printer settings for proper scale.

PYRAMID TECHNOLOGIES, INC.
CURRENCY VALIDATION EXPERTS

Once configured with the card, the acceptor will remember these settings, even if power is removed. When you fill in the card, use a black felt tip marker and fill the selected block completely making sure no marks are outside the block. Note: As a service to our customers, Pyramid Technologies, Inc. will configure each acceptor to your requirements free of charge. Just ask!

Fill out the Configuration Card according to the table below:

Section Number on Configuration Card	Description
<p>Section 1 These lines select the type of Interface that you want to use. If you are unsure about your selection, see the Interface Section of this manual. You can select only <u>one</u> interface type.</p>	<p>Pulse/Serial- Mars™ - Pulse or 600 baud serial. RS-232- True RS-232 or TTL RS-232 interface. Always Enabled- Acceptor always enabled mode. MDB- Multi-Drop Bus \$1/\$5 Credit Line Parallel - Similar to Smiley™ Parallel mode. Others- Not Used.</p>
<p>Section 2 These lines select the Pulses Per Dollar. For Pulse mode, fill in the Blocks to add up the total number of Pulses Per Dollar that you desire. Fill out “None” if you are not using any type of pulse mode.</p>	<p>Fill in the Blocks to add up the total number of Pulses Per Dollar that you desire. For example, if you want ten (10) pulses per dollar, fill in the “8” and “2” Blocks. Note: If you wish to use the Mars 600 baud serial mode instead of Pulse, then fill in the “None” Block. If you select a number for Pulses Per Dollar, the acceptor <u>always</u> assumes Pulse Mode (this eliminates the need for the usual “Jumper Plug”).</p>
<p>Section 3(Pulse Speed) This line selects the Slow or Fast Pulse. The Slow Pulse is a 50 msec on, 300 msec off pulse. The Fast Pulse is a 50 ms on, 50 ms off</p>	<p>Fill in the appropriate Block. Note: If you are not using the pulse mode, don't fill out this section.</p>
<p>Section 3 (Lighted Bezel) This line selects how the Bezel lighting will appear to the customer. The Bezel can be selected to be always on or can set to be flashing when the acceptor is enabled. In either case, the Bezel is off when the acceptor is disabled, or when the acceptor has a problem.</p>	<p>Fill in the appropriate Block. You must select one of the options here.</p>
<p>Section 4 (Enable Bills) These lines determine which bills you want enabled. Please remember that if you ordered a \$1-\$5 acceptor, it cannot be enabled to accept \$10, \$20, \$50 or \$100 bills, etc.</p>	<p>Fill in the appropriate Block to enable a bill. The other lines labeled “Bill 7” through “Bill 12” are for special bills or custom configurations only.</p>
<p>Section 5 (Security Level) This line is used to select the security of the bill acceptor. Select either low or high security.</p>	<p>Low security should be used when the user knows that the likelihood of counterfeiting is low. High security should be used when the acceptor is configured to accept high denomination currency. You must select one option.</p>
<p>Section 5 (Insert Direction) This line is used to select the direction of bill acceptance. Bills can be accepted in all four directions or “Face up, left” which means face up, black seal first.</p>	<p>Select the appropriate direction of insertion. You must select one option.</p>

Configuring the Bill Acceptor using the Configuration Card

- Make sure power is applied to the bill acceptor. For Apex SPECTRA, make sure all DIP Switch positions are set to OFF.
- Press and hold the Diagnostic Pushbutton located at the left rear of the bill acceptor (looking at the acceptor from the rear). Hold the Diagnostic Pushbutton for at least ten (10) seconds, then release.
- The bezel lighting on the front will flash white rapidly signifying to insert Configuration Card.
- Insert the Configuration Card into the acceptor, arrows first, printed side face up.
- The acceptor will hold the Configuration Card for a second or two, then feed it back to you.
- If the bezel lights are flashing white rapidly, the acceptor has read the Configuration Card correctly. The configuration is now in permanent memory in the bill acceptor. The acceptor will reset itself. You can now begin using the acceptor.
- If the bill acceptor has not read the Configuration Card correctly, the bezel light color will flash to signify an error in a particular section according to the chart below. If this occurs, make sure that "Section" is filled in neatly. The bill acceptor will stay in the Configuration Mode until it has correctly read a Configuration Card, or if you remove power to the acceptor.

<u>Section that Failed</u>	<u>Flash Color Code</u>
Section 1 Fail	Flash Red
Section 2 Fail	Flash Violet
Section 3 Fail	Flash Green
Section 4 Fail	Flash Yellow
Section 5 Fail	Flash Blue
Configuration OK	Flash White, Then Reset

Flash Programming Primer

Downloading new software to the Apex SPECTRA bill acceptor is accomplished using a Pro-2 Handheld Programmer or Windows PC with Acceptor Tools Software (free download on website) with 05AA0026 USB Cable.

Instead of using an EPROM to hold the bill acceptor software, Pyramid Technologies, Inc. chose to use a Flash Device installed on the SPECTRA bill acceptor's Microprocessor Board. Using this device, there is no need to open the acceptor to change software. To change the acceptor's software, you will plug the PC Flash Download Cable, or Pro-2 Handheld Programmer, into the six (6) pin connector located next to the Diagnostic Pushbutton (left rear of the acceptor as seen from the back). After loading the required software onto the PC or Pro-2, you can download new software to any bill acceptor at any location. The only requirement is that the acceptor has power applied. The PC software has the added benefit of performing advanced diagnostics on the bill acceptor, and setting the configuration.

Our web site (www.pyramidacceptors.com) has the latest available software located in our "Download" Section, and documentation is available upon request, or from the "Support" section of our web site.

Bill Acceptor Testing

- Apply power to the machine. The bill acceptor will cycle its motor and stacker, if so equipped.
- Check the bezel lighting. Based on the configuration you programmed, the bezel lights should be on solid or flashing at a one second rate. This will indicate that the acceptor is ready to take bills.
- Insert one of each denomination that can be accepted and verify that proper credit is given to the machine.

If the acceptor does not accept a particular bill or does not credit the machine properly, re-check the configuration that you programmed using the Configuration Card.

The Apex SPECTRA bill acceptor has built in diagnostic abilities. These can be accessed using the Diagnostic Pushbutton, located at the left rear of the bill acceptor (viewed from the back).

Pushbutton Operation

The Diagnostic Pushbutton on the Apex SPECTRA bill acceptor is utilized for two (2) functions. They are:

1. Diagnostics of the acceptor using the front bezel lighting.
2. Configuration of the acceptor using the Configuration Card.

Refer to Configuration/Configuration Card Section for details on configuring the acceptor.

Diagnostic Features

To enter the Diagnostic Mode, the acceptor must have power. The front bezel lighting is used to flash a certain color to indicate an error, if one exists.

To enter the Diagnostic Mode, push and hold the Diagnostic Pushbutton located at the left rear of the acceptor (viewed from the back). Hold it for at least one (1) second, but no more than five (5) seconds, then release.

Note: Holding it longer than 10 seconds will put the acceptor into a Configuration Mode and it will expect to have the Configuration Card inserted next. If you have accidentally entered this mode, cycle the acceptor power and start again.

Look at the front bezel of the bill acceptor. It will be flashing a color code. The particular color of lights flashing corresponds to the error code listed on the next page.

To exit this mode, either let the acceptor sit (it will automatically exit this mode after thirty (30) seconds), or press the button again for 1-5 seconds. (Remember, don't hold for longer than five (5) seconds.)

Maintenance

The Apex SPECTRA bill acceptor is relatively maintenance free. An occasional cleaning is all that is needed to keep the acceptor in top operation. ***Please Visit the "service" section of our website to view videos explaining how install, clean, program, and troubleshoot the Apex SPECTRA bill acceptor.***

To clean the acceptor:

- Remove power from the machine.
- If equipped with a stacker, unlatch the cassette by pushing in the top latch and lifting the cassette up and out.
- Unplug the I/O connector and/or power connector from the right side of the acceptor.
- Remove the Lower Transport by pushing in the latch located on the bottom of the acceptor at the rear. Gently pull the Lower Transport out of the assembly.
- Clean the bill path using a soft cloth or towel. Do not use any cleaners other than a 50/50 mixture of water and isopropyl alcohol.

NOTE: Pay particular attention to the gray oval pieces of plastic in the lower and upper transport area. They must be cleaned well for proper operation.

Do not use any oils or silicon spray on the acceptor!

Front Bezel Color Light Codes

The flash codes shown correspond to the Apex SPECTRA bill acceptor error. The acceptor will flash the error code, then wait 3 seconds and flash it again.

Flashing Color Code	Meaning of Flashing Code	Corrective Action
Flashing White	Motor Failure	Contact authorized service center
Flashing Red	Acceptor/Stacker Jammed or Punch Not Home	Remove the cassette and Lower Transport to inspect for foreign objects. Clean if necessary.
Flashing Green	The cassette is full of currency	Remove the cassette and empty it.
Flashing Purple	The cassette has been removed.	Replace the cassette.
Flashing Yellow	Disabled By Host	Reset host machine
Solid White	No errors	No corrective action necessary
Rapid Flashing Blue	OAS Lock-Up	Unit will reset itself after a given amount of time. If unit does not reset try cleaning bill path.

If any of the corrective actions do not rectify the issues being experienced, please contact your local authorized service center or contact us direct at 480-641-9733.

Connection Details- Figure 1

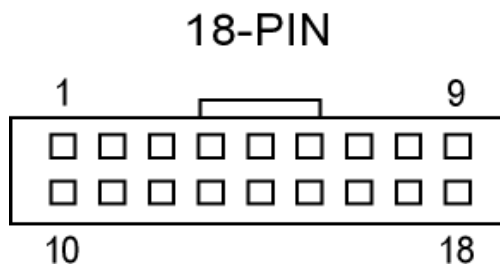

18-pin I/O connector
(Looking at the acceptor)

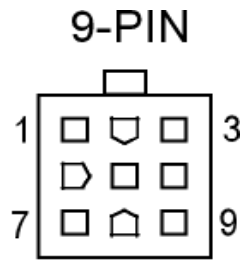

9-pin 120 VAC or 24 VAC connector
(View of connector)

18-pin Mating Connector

P/N 22-55-2182 (Housing)
Female Contact P/N 16-02-0086

9-pin Mating Connector

Amp Mate-N-Lock 9-pin P/N 172169-1
Amp Female Pin P/N 170362-1

Molex
Molex

Pin	18-Pin Connector Function (wire color)
1	\$1 Low-level credit line output (Brown)
2	~INT line for Mars 600-baud mode (Orange)
3	Serial/~Pulse or (Yellow)
4	DC Power Ground (Black)
5	TXD for Mars 600 or TTL RS232 (Green)
6	Not Used (Blue)
7	Not Used (Gray)
8	Not Used (Pink)
9	Not Used (White)
10	Out of Service line (pulled low) (Tan)
11	+12 VDC Power (Red)
12	~Acceptor Enable (Pull low to enable) (Violet)
13	330 Ohm resistor to +5 VDC for LED (White/Orange)
14	~Send line for Mars 600 (White/Blue)
15	Not Used (White/Yellow)
16	RXD for TTL RS232 (White/Red)
17	Not Used (White/Green)
18	Not Used (White/Gray)

Pin	9-Pin Connector Function
1	120 VAC Neutral Inhibit
2	120 VAC Neutral Enable
3	120 VAC Hot Enable
4	120 VAC Hot Power (Not used for 24 VAC model)
5	No Connection (24 VAC hot for 24 VAC model)
6	120 VAC Neutral Power (24VAC Neutral for 24 VAC model)
7	Bill Acceptor Relay Contact (Normally Open)
8	Bill Acceptor Relay Contact (Common)
9	No Connection

Modes of Operation

Pulse/Serial Mode

Note: To enable this mode on the Apex SPECTRA bill acceptor, make sure the Configuration Card has been configured for "Pulse/Serial" mode.

These modes are compatible with the Mars VFM style bill acceptors that use the Pulse/Serial modes. Figure 1 (above) shows the connectors to be used for this mode of operation.

Pulse Mode

The pulse interface mode can be operated in two ways. The first is a "High Level" mode that uses 120 VAC as the control signals. The second is a "Low Level" mode that uses low voltage signals.

High Level Pulse Mode

This interface is typically used in can vending machines. It uses 120 VAC to enable/disable the acceptor. The output of the bill acceptor is a pulse output via relay contacts. You must be using Pyramid Technologies, Inc. optional 120 VAC power supply for this mode to work.

High Level Pulse Mode- Inputs and Outputs

The inputs and outputs (I/O) are located on the 9-pin connector and 18-pin connector (See Figure 1 above) for the High Level Mode.

The I/O descriptions for the 9-pin connector are as follows:

Pin 4- 120 VAC Hot (Black wire). Connect to 120 VAC Hot (for AC power).

Pin 6- 120 VAC Neutral (White wire). Connect to 120 VAC Neutral (for AC power).

Pin 3- 120 VAC Hot Enable (Red wire). Connect to 120 VAC Hot to enable acceptor. Leave floating to disable acceptor. **(Note: Low cost 120 VAC supply does not have this connection. It is a no-connect.)**

Pin 2- 120 VAC Neutral Enable (Orange wire). Connect to 120 VAC Neutral to enable acceptor. Leave floating to disable acceptor. **(Note: Low cost 120 VAC supply does not have this connection. It is a no-connect.)**

Pin 1- 120 VAC Neutral Inhibit (Green wire). Connect to 120 VAC Neutral to disable acceptor. If left floating, may disable acceptor, based on the state of the 120VAC Hot Enable line. **(Note: Low cost 120 VAC supply does not have this connection. It is a no-connect.)**

Pins 7 and 8- (Brown wire-7, Blue wire-8) Bill acceptor relay contacts capable of 1 amp resistive load at 120 VAC. Based on how you configured the acceptor, they will put out a 50 msec on/50 msec off pulse, or a 50 msec on/300 msec off pulse. Due to relay contact bounce, it is recommended that the software engineer incorporate a 10 msec software delay to debounce the relay contacts.

The Input/Output descriptions for the 18-pin connector are as follows:

Pin 3 (Yellow wire) - Serial/~Pulse Line. Pull low (Connect to Pin 4 (Black wire), which is Ground) to enable the Pulse mode of operation. **Note:** You **do not** need to make this connection if you have selected "Pulse/Serial" on the Configuration Card and you have specified some number for the Pulses Per Dollar. By selecting some number for Pulses Per Dollar, you have told the acceptor that you are in Pulse mode, not Mars Serial Mode. This eliminates the need for this connection, commonly called a "Pulse Jumper Plug".

In addition, both the 120 VAC model and 12 VDC model have an "Out of Service" output located on Pin 10 (Tan wire) of the 18-pin connector. It is a normally high, open-collector output transistor that is pulled low when the acceptor is Out of Service. (5-12 VDC at 40 mA Max.) Pin 13 (White/Orange wire) of the 18-pin connector has a 330 ohm resistor tied to +5VDC to power an LED.

Low Level Pulse Mode

The Low Level Pulse Mode can operate using either the optional 120 VAC power supply, or by using 12 VDC applied to the bill acceptor. Using the optional 120 VAC power supply, the output can be taken from the relay contacts (Pin 7 and 8 on the 9-pin connector). Without the 120 VAC power supply, the output is on the 18-pin connector and is a normally high, open-collector transistor output.

Low Level Pulse Mode- Connections:

Power

120 VAC Model- Connect 120 VAC power to Pins 4 (Black wire) and 6 (White wire) on the 9-pin connector (see Figure 1).

24 VAC Model- Connect 24 VAC power to Pins 5 (Black wire) and 6 (White wire) on the 9-pin connector (see Figure 1).

12 VDC Model- Connect +12 VDC to Pin 11 (Red wire) on the 18-pin connector (see Figure 1). Connect DC ground to Pin 4 (Black wire) on the 18-pin connector.

Inputs (0-5 VDC Operation Only)

Pin 12 (Violet wire) on the 18-pin connector- Accept Enable line. Bring low to enable the acceptor. (Tie to DC ground, Pin 4 (Black wire) on the 18-pin connector to always enable the acceptor.)

Pin 3 (Yellow wire) on the 18-pin connector- Serial/~Pulse Line. Pull low (connect to Pin 4 (Black wire), which is DC Ground) to enable the Pulse Mode of operation. **Note:** You **do not** need make this connection if you have selected "Pulse/Serial" on the Configuration Card and you have specified some number for the Pulses Per Dollar. By selecting some number for Pulses Per Dollar, you have told the acceptor that you are in Pulse Mode, not Mars Serial Mode. This eliminates the need for this connection, commonly called a "Pulse Jumper Plug".

Outputs

120 VAC or 24 VAC Model- You can use the relay output on Pins 7 (Brown wire) and 8 (Blue wire) of the 9-pin connector, or you can use the normally high, open-collector output transistor on Pin 1 (Brown wire) on the 18-pin connector. (5-12 VDC at 40 mA Max.)

12 VDC Model- Use the normally high, open-collector output transistor on Pin 1 (Brown wire) on the 18-pin connector (5-12 VDC at 40 mA Max.).

In addition, the 120 VAC model, 24 VAC model and 12 VDC model have an "Out of Service" output located on Pin 10 (Tan wire) of the 18-pin connector. It is a normally high, open-collector output transistor that is pulled low when the acceptor is Out of Service. (5-12VDC at 40 mA Max.) Pin 13 (White/Orange wire) of the 18-pin connector has a 330 ohm resistor tied to +5VDC to power an LED.

Serial Mode- (Works with 12 VDC, 120 VAC and 24 VAC models of the SPECTRA Bill Acceptor.)

This Interface is Mars compatible. This interface is a non-isolated interface. (TTL/CMOS compatible.) This interface operates at 600 baud, 1 start bit, 1 stop bit and 8 data bits. The Apex SPECTRA bill acceptor will pull the Interrupt line low when it has a serial message to send to the host. The host machine will pull the Send line low when it can receive this serial message. The SPECTRA will then output a Credit Message if the bill is recognized. A Reject Message is sent if the bill is not recognized. After the Credit message is sent to the host, the Enable line is to be pulsed high within 5 msec if the host wants to return the bill to the customer. If the Enable Line remains low, the acceptor will accept the bill and send a Vend Message to the host. The Host machine can tell the acceptor to resend any particular message by bringing the Send Line high and pulse it low within 2-4 msec.

Serial Mode- Connections

120 VAC Model- Connect 120 VAC power to Pins 4 (Black wire) and 6 (White wire) on the 9-pin connector (see Figure 1).

24VAC Model- Connect 24 VAC power to Pins 5 (Black wire) and 6 (White wire) on the 9-pin connector (see Figure 1).

12 VDC Model- Connect +12 VDC to Pin 11 (Red wire) on the 18-pin connector (see Figure 1). Connect DC Ground to Pin 4 (Black wire) on the 18-pin connector.

Inputs and Outputs for Serial Interface. (Inputs are 0-5V DC Operation Only)

Pin Number wire Color	Signal Name	Function
Pin 2 Orange wire	~Interrupt Line	Request to send data to host.
Pin 3 Yellow wire	Serial/Pulse Mode Select Line	Must be left floating to enable serial mode. (No Connect.) Also make sure you have selected "None" for Pulses Per Dollar selection on the Configuration Card.
Pin 4 Black wire	Ground	DC ground
Pin 5 Green wire	TXD (Data Output)	Transmit Data Line from acceptor.
Pin 10 Tan wire	Out Of Service	Pulled low by the acceptor when the acceptor is out of service or when the stacker (if so equipped), is full. (5-12 VDC at 40 mA Max.)
Pin 11 Red wire	+12 VDC Power	+12V Acceptor Power. Note: Do not connect if the optional 120 VAC supply is used!
Pin 12 Violet wire	Acceptor Enable	Pull low to enable the acceptor.
Pin 13 White/Orange wire	LED Power	LED Power can be obtained here. This output is a 330 ohm resistor tied to +5V.
Pin 14 White/Blue wire	~Send Line	Host Ready Signal.

The table below shows the Data that can be sent from the SPECTRA bill acceptor to the Host.

Message	Bit 7	Bit 6	Bit 5	Bit 4	Bit 3	Bit 2	Bit 1	Bit 0	Hex Value
\$1 Credit	1	0	0	0	0	0	0	1	81H
Not Used	1	0	0	0	0	0	1	0	82H
\$5 Credit	1	0	0	0	0	0	1	1	83H
\$10 Credit	1	0	0	0	0	1	0	0	84H
\$20 Credit	1	0	0	0	0	1	0	1	85H
\$50 Credit	1	0	0	0	0	1	1	0	86H
\$100 Credit	1	0	0	0	0	1	1	1	87H
Reserved	1	0	0	0	1	0	0	0	88H
Vend	1	0	0	0	1	0	0	1	89H
Return	1	0	0	0	1	0	1	0	8AH
Reject	1	0	0	0	1	0	1	1	8BH
Failure	1	0	0	0	1	1	0	0	8CH
Full or Jam	1	0	0	0	1	1	0	1	8DH

Always Enabled Mode of Operation

This mode of operation is the simplest to understand. In this mode, the acceptor is always enabled. It will accept all valid bills that are programmed to be accepted by the Configuration Card. Note: to enable this mode on the acceptor, make sure the Configuration Card has been configured for "Always Enabled" mode. The output of the bill acceptor is either the relay contacts (if a 120 VAC optional supply is used), or the Low Level Non-Isolated Credit Line (see below for details).

Always Enabled Mode- Connections:

Power

120 VAC Model- Connect 120 VAC power to Pins 4 (Black wire) and 6 (White wire) on the 9-pin connector (see Figure 1).

24 VAC Model- Connect 24 VAC power to Pins 5 (Black wire) and 6 (White wire) on the 9-pin connector (see Figure 1).

12 VDC Model- Connect +12 VDC to Pin 11 (Red wire) on the 18-pin connector (see Figure 1). Connect DC Ground to Pin 4 (Black wire) on the 18-pin connector.

In addition, both the 120 VAC model and 12 VDC model have an "Out of Service" output located on Pin 10 (Tan wire) of the 18-pin connector. It is a normally high, open-collector output transistor that is pulled low when the acceptor is Out of Service. (5-12 VDC at 40 ma Max.) Pin 13 (White/Orange wire) of the 18-pin connector has a 330 ohm resistor tied to +5VDC to power an LED.

Outputs

120 VAC or 24 VAC Model- You can use the relay output on Pin 7 (Brown) and Pin 8 (Blue) of the 9-pin connector, or you can use the normally high, open-collector output transistor on Pin 1 (Brown wire) on the 18-pin connector. (5-12 VDC at 40 mA Max.)

12 VDC Model- Use the normally high, open-collector output transistor on Pin 1 (Brown wire) on the 18-pin connector (5-12 VDC at 40 mA max.)

All outputs will send the number of pulses and pulse speed as set by the Configuration Card.

RS-232 Mode (True RS-232 and TTL RS-232)

Note: To enable this mode on the acceptor, make sure the Configuration Card has been configured for "RS-232" mode. In this mode, the user has a choice of True RS-232 levels or TTL levels.

TTL (5 VDC) levels are available in the 120 VAC model, 24 VAC and 12 VDC model of the Apex SPECTRA bill acceptor. Order our Acceptor I/O Harness, Generic (P/N 05AA0002). With this cable, you must manually connect the wires to your machine.

True RS-232 levels are available only in the 12 VDC Model of the Apex SPECTRA bill acceptor. In the 12 VDC version, the harness has a DB-9 connector and hard drive connector installed to ease customer installation. Order RS-232 Communication Harness (P/N 05AA0009) to have this ability if you use RS-232. If you use USB, order USB Communication Harness (P/N 05AA0023).

This RS-232 mode uses a three wire interface. This interface uses a Transmit Line (TXD), a Receive Line (RXD) and DC ground (Gnd).

This RS-232 Interface is compatible with the interface used on Mars™ GL5™ style acceptors. It is a polled interface where the host machine is the Master and the bill acceptor is the Slave. For RS-232 communication protocol details, see the "support" section of our website.

TTL RS-232 Mode Power and I/O Connections (Refer to Figure 1 for Pinouts)

Pin Function & Location	SPECTRA 12 VDC Version	SPECTRA 120 VAC or 24 VAC Version
DC Ground- Pin 4 (Black wire) on the 18-pin connector.	DC communication ground and DC power ground.	DC communication ground.
+12VDC- Pin 11 (Red wire) on the 18-pin connector.	12VDC acceptor power.	Do not use this pin for 120 VAC or 24 VAC version!
120 VAC Hot- Pin 4 (Black wire) on the 9-pin connector.	Do not use this pin for 12 VDC version.	120 VAC hot.
24 VAC Hot- Pin 5 (Black wire) on the 9-pin connector.	Do not use this pin for 12 VDC version.	24 VAC hot.
120 VAC or 24 VAC Neutral- Pin 6 (White wire) on the 9-pin connector.	Do not use this pin for 12 VDC version.	120 VAC neutral or 24 VAC neutral.
TXD Line- Pin 5 (Green wire) on the 18-pin connector.	TXD- SPECTRA Transmit Line. Connect to Receive line on your equipment.	TXD- SPECTRA Transmit Line. Connect to Receive line on your equipment.
RXD Line- Pin 16 (White/Red wire) on the 18-pin connector.	RXD- SPECTRA Receive Line. Connect to Transmit line on your equipment.	RXD- SPECTRA Receive Line. Connect to Transmit line on your equipment.

True RS-232 Mode Power and I/O Connections

Pin Function and Location	SPECTRA 12VDC Version
DC Ground- Pin 2 (Black wire) on the Hard Drive connector.	DC power ground.
+12VDC- Pin 1 (Yellow wire) on the Hard Drive connector.	12 VDC acceptor power.
Communication Ground- Pin 5 (Black wire) on the DB-9 connector.	DC communication ground.
TXD Line- Pin 3 (Green wire) on the DB-9 connector.	Connected to TXD line from your PC. (PC TXD line)
RXD Line- Pin 2 (White wire) on the DB-9 connector.	Connected to RXD line from your PC. (PC RXD line)

MDB Mode of Operation

Note: To enable this mode on the acceptor, make sure the Configuration Card has been configured for "MDB" mode. Our MDB interface uses the standard MDB connector (see below) for communication.

6-PIN (MDB)

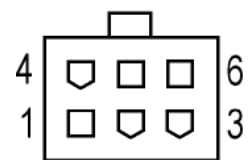

MDB Mode Power and I/O Connections

Pin Location	Pin Description
Pin 1	+24 VDC Power
Pin 2	DC power return
Pin 3	Not used
Pin 4	Master Receive
Pin 5	Master Transmit
Pin 6	Communications Common

Parallel Mode of Operation

Note: To enable this mode on the acceptor, make sure the Configuration Card has been configured for "Parallel" mode. The Parallel mode is compatible with the Innovative Technologies™ "Smiley™" bill acceptor.

In this mode, a single output is applied to one of four Vend lines to show which bill has been accepted. This allows you to have up to four denominations of bills to be accepted. Also provided in this interface is an Alarm line to indicate an abnormal condition. An Escrow line is also provided to allow more control over which bill is accepted by the Apex SPECTRA bill acceptor.

This mode can be used in our 12 VDC models as well as our 120 VAC and 24 VAC models.

Interface Operation

The Inhibit line is used to enable the Apex SPECTRA acceptor. Pull it low to enable the acceptor, high to disable. The Alarm output will go low for 100 msec to signal an abnormality or error. A Vend Line will go low for 100 msec when a particular bill is recognized. Vend Lines 1-4 correspond to US bills \$1, \$5, \$10 and \$20. If the Escrow Line is not held low, the acceptor will accept a bill and send the appropriate signal via the Vend Line. If the Escrow Line is held low and a bill is inserted, the Apex SPECTRA bill acceptor will send out a "Credit" signal telling you what the value of the bill is (by toggling the appropriate Vend Line). If the Escrow Line is not brought high or the Inhibit Line goes high during a 30-second period, the bill will be rejected. If the user brings the Escrow Line high (and leaves the Inhibit line low) during the 30 second period, the acceptor will accept the bill and send out a "Vend" signal on the appropriate Credit Line. The Vend signal will not be issued if the bill jams or a "Stealing" attempt is seen by the acceptor. In this case, the bill will be rejected and the acceptor will toggle the Alarm Line.

Parallel Mode Power and I/O Connections (Refer to Figure 1 for Pinouts)

Pin Function & Location	SPECTRA 12VDC Version	SPECTRA 120 VAC or 24 VAC Version
DC Ground- Pin 4 (Black wire) on the 18-pin connector.	DC communication ground and DC power ground.	DC communication ground
+12 VDC- Pin 11 (Red wire) on the 18-pin connector.	12 VDC acceptor power	Do not use this pin for 120 VAC version.
120 VAC Hot- Pin 4 (Black wire) on the 9-pin connector.	Do not use this pin for 12 VDC version.	120 VAC Hot
24 VAC Hot- Pin 5 (Black wire) on the 9-pin connector.	Do not use this pin for 12 VDC version.	24 VAC hot.
120 VAC or 24 VAC Neutral- Pin 6 (White wire) on the 9-pin connector.	Do not use this pin for 12 VDC version.	120 VAC or 24 VAC Neutral
Alarm- Pin 13 (White/Orange wire) on the 18-pin connector.	Normally high, pulled low for 100 msec to show abnormal event. (0-5V DC operation).	Normally high, pulled low for 100 msec to show abnormal event. (0-5V DC Operation).
Escrow- Pin 14 (White/Blue wire) on the 18-pin connector.	Input used to control the Escrow function (0-5V DC operation).	Input used to control the Escrow function (0-5V Operation).
Inhibit- Pin 12 (Violet wire) on the 18-pin connector.	Input used to Enable (low) or disable (high) the acceptor (0-5VDC operation).	Input used to Enable (low) or disable (high) the acceptor. (0-5VDC operation)
Credit/Vend Line 1 (\$1)- Pin 1 (Brown wire) on the 18-pin connector.	Open-collector, normally high output. Pulled low for 100 msec when this bill is recognized.	Open-collector, normally high output. Pulled low for 100 msec when this bill is recognized.
Credit/Vend Line 2 (\$5)- Pin 2 (Orange wire) on the 18-pin connector.	Open-collector, normally high output. Pulled low for 100 msec when this bill is recognized.	Open-collector, normally high output. Pulled low for 100 msec when this bill is recognized.
Credit/Vend Line 3 (\$10)- Pin 10 (Tan wire) on the 18-pin connector.	Open-collector, normally high output. Pulled low for 100 msec when this bill is recognized.	Open-collector, normally high output. Pulled low for 100 msec when this bill is recognized.
Credit/Vend Line 4 (\$20)- Pin 5 (Green wire) on the 18-pin connector.	Open-collector, normally high output. Pulled low for 100 msec when this bill is recognized.	Open-collector, normally high output. Pulled low for 100 msec when this bill is recognized.

Configuration Card

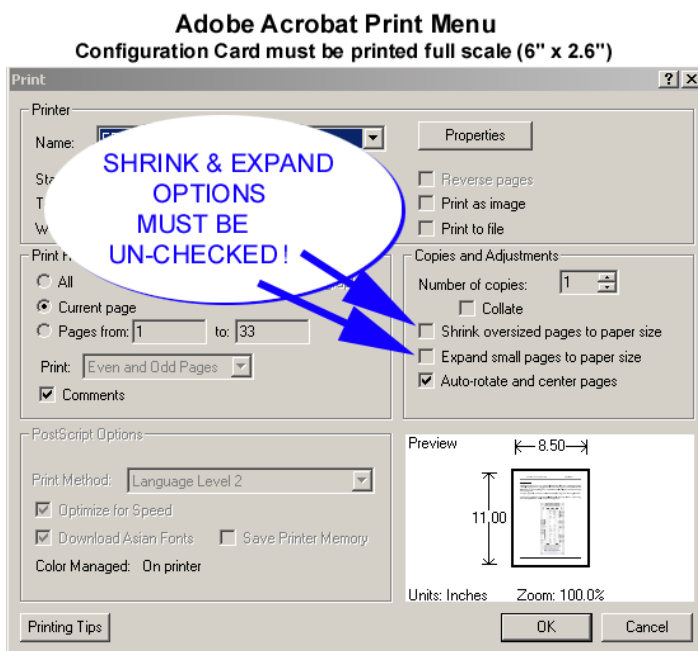

The Configuration Card is to be copied from this manual using either a laser or a bubble jet copier. Use standard photocopy paper. After copying it, **make sure that it matches the original size of 6.0 x 2.6 inches (152 x 66 mm).**

Note: Copiers occasionally change the size of printed materials. This is why you should compare the copied card to the original card.

To use your copy, fill in the desired selections with **black felt-tipped ink** and cut the Configuration Card out along the solid line. If you are printing this manual from a PDF file (which may be downloaded from our web site), **you must turn off any "shrink" or "expand" settings from within the print menu** to be sure the card is printed at the proper scale.

INSERT THIS SIDE UP, THIS END FIRST. USE BLACK FELT-TIPPED INK, FILL OVALS COMPLETELY



Pulse/Serial \$1/\$5 Credit Lines

MDB \$1-20 Credit Lines

RS-232 Always Enabled

Parallel Hi

Special 1 Special 2

section 1

Select only one Interface Type

section 2

Pulses per Dollar (sum of selected values)

64 4

32 2

16 1

8 None

Example: For 50 ppd, fill in the ovals for 32, 16, and 2, (32+16+2 = 50)

Pulse Speed: Slow Fast

Lighted Bezel: Solid On Flashing

section 3

section 4

Select Bills to Enable

Bill 1 (\$1) Bill 2 (\$5)

Bill 3 (\$10) Bill 4 (\$20)

Bill 5 (\$50) Bill 6 (\$100)

Bill 7 Bill 8

Bill 9 Bill 10

Bill 11 Bill 12

Example: To accept USA \$1, \$5, and \$10, fill in the ovals for Bill 1, Bill 2, and Bill 3.

Security Level: High Low

Insert Direction: Face up, Left 1st All 4 Ways

section 5



This Configuration Card should be printed on standard copy paper, measuring 6.0 x 2.6 inches (152 x 66 mm).

If printing from a .PDF file, turn off the "shrink to fit" option in your printer settings for proper scale.



PYRAMID TECHNOLOGIES, INC.

CURRENCY VALIDATION EXPERTS

Need Assistance?
Call 480-641-9733
7:30 to 2:30 Pacific Time
Let us Help!

INSERT THIS SIDE UP, THIS END FIRST. USE BLACK FELT-TIPPED INK, FILL OVALS COMPLETELY



Pulse/Serial \$1/\$5 Credit Lines

MDB \$1-20 Credit Lines

RS-232 Always Enabled

Parallel Hi

Special 1 Special 2

section 1

Select only one Interface Type

section 2

Pulses per Dollar (sum of selected values)

64 4

32 2

16 1

8 None

Example: For 50 ppd, fill in the ovals for 32, 16, and 2, (32+16+2 = 50)

Pulse Speed: Slow Fast

Lighted Bezel: Solid On Flashing

section 3

section 4

Select Bills to Enable

Bill 1 (\$1) Bill 2 (\$5)

Bill 3 (\$10) Bill 4 (\$20)

Bill 5 (\$50) Bill 6 (\$100)

Bill 7 Bill 8

Bill 9 Bill 10

Bill 11 Bill 12

Example: To accept USA \$1, \$5, and \$10, fill in the ovals for Bill 1, Bill 2, and Bill 3.

Security Level: High Low

Insert Direction: Face up, Left 1st All 4 Ways

section 5



This Configuration Card should be printed on standard copy paper, measuring 6.0 x 2.6 inches (152 x 66 mm).

If printing from a .PDF file, turn off the "shrink to fit" option in your printer settings for proper scale.



PYRAMID TECHNOLOGIES, INC.

CURRENCY VALIDATION EXPERTS

Need Assistance?
Call 480-641-9733
7:30 to 2:30 Pacific
Let us Help!

INSERT THIS SIDE UP, THIS END FIRST. USE BLACK FELT-TIPPED INK, FILL OVALS COMPLETELY



<input type="checkbox"/>	Pulse/ Serial	\$1/\$5 Credit Lines	<input type="checkbox"/>
<input type="checkbox"/>	MDB	\$1-20 Credit Lines	<input type="checkbox"/>
<input type="checkbox"/>	RS-232	Always Enabled	<input type="checkbox"/>
<input type="checkbox"/>	Parallel	Hi	<input type="checkbox"/>
<input type="checkbox"/>	Special 1	Special 2	<input type="checkbox"/>

section 1

Select only one Interface Type

section 2

Pulses per Dollar (sum of selected values)

<input type="checkbox"/>	64	4	<input type="checkbox"/>
<input type="checkbox"/>	32	2	<input type="checkbox"/>
<input type="checkbox"/>	16	1	<input type="checkbox"/>
<input type="checkbox"/>	8	None	<input type="checkbox"/>

Example:
For 50 ppd, fill in the ovals for 32, 16, and 2, (32+16+2 = 50)

Pulse Speed: Slow Fast

Lighted Bezel: Solid On Flashing

section 3

section 4

Select Bills to Enable

<input type="checkbox"/>	Bill 1 (\$1)	Bill 2	<input type="checkbox"/>	(\$5)
<input type="checkbox"/>	Bill 3 (\$10)	Bill 4	<input type="checkbox"/>	(\$20)
<input type="checkbox"/>	Bill 5 (\$50)	Bill 6	<input type="checkbox"/>	(\$100)
<input type="checkbox"/>	Bill 7	Bill 8	<input type="checkbox"/>	
<input type="checkbox"/>	Bill 9	Bill 10	<input type="checkbox"/>	
<input type="checkbox"/>	Bill 11	Bill 12	<input type="checkbox"/>	

Example:
To accept USA \$1, \$5, and \$10, fill in the ovals for Bill 1, Bill 2, and Bill 3.

Security Level: High Low

Insert Direction: Face up, Left 1st All 4 Ways

section 5



This Configuration Card should be printed on standard copy paper, measuring 6.0 x 2.6 inches (152 x 66 mm).

If printing from a .PDF file, turn off the "shrink to fit" option in your printer settings for proper scale.



PYRAMID TECHNOLOGIES, INC.

CURRENCY VALIDATION EXPERTS

Need Assistance?
Call 480-641-9733
7:30 to 2:30 Pacific Time
Let us Help!